

Smart Electricity Meter Design and Key Parts Molding Process Development

Zhanfeng Zhao

Wenzhou Polytechnic, Wenzhou, 325035, China

Abstract

Through the analysis of the technical specifications of smart electricity meters, combined with the characteristics of regional enterprises, the mechanical and electrical structures of smart meter are designed. The mechanical structure layout is reasonable, effectively accommodate control components and mechanical parts, and at the same time facilitate mass production moulds, and has the advantages of manufacturing process. The electrical structure is in line with the latest 5G signal transmission and network data collection, remote metering, and remote operation and maintenance. The key components of the smart meter have been formulated, and the model of the mould is designed to provide equipment supports for the mass production of the meter. Combined with the processing process of related components, the key level of molding has been studied, providing strong level support for enterprises to apply new technologies and production quality products.

Keywords

Smart Meter; Mechanical Structure; Electrical Structure; Molding Process.

1. Introduction

Electric energy measurement products are trade settlement products, and the quality requirements for products are very high. After the product installation is required, the entire life cycle is required to be stable and reliable during the entire life cycle[1-3]. Because the smart meter has greatly improved the function of the traditional meter in terms of function, the direct performance of the external performance of the smart meter has changed a lot with the mechanical structure of the key components of the smart meter. Carry out corresponding process innovation[4-7]. Traditionally, the structural parts of the smart meter are usually produced by molding after the mechanical structure design is completed.

For higher vocational education machinery majors, especially molding design and manufacturing program, intelligent manufacturing and additive manufacturing, especially smart meters, etc., such as similar functional products such as traditional mechanical parts, their mechanical structure research and development[8-10]. The trial production has produced fundamental changes. From the perspective of teaching, how to combine new technologies with traditional craftsmanship, promote teaching knowledge, skills, and craftsmanship, and use the latest technical training to better serve new products and promote intelligent manufacturing. The intelligent design and manufacturing products under the digital economy conditions are intelligent, digital, and rapid design. Wenzhou Polytechnic Related teaching programs, especially the mould major program, have actively carried out the reform of professional talent training plans in recent years. In the professional courses, the proportion of traditional craftsmanship and new processes has been continuously optimized. However, the courses of professional talent training are more of the teaching and training of basic skills such as basic concepts and basic principles. How to combine the research and development and development system of real mechanical and electrical products, especially the smart electricity meter

products that are upgraded and transformed for the national smart grid to meet the people's good life for a better life. Key component design and molding process development projects, which is of great significance for the improvement of teachers' teaching ability and the implementation of professional new technology application courses.

2. Smart Electricity Meter Structure Design

Intelligent meter infrastructure is mainly composed of smart meters, communication systems, and meter information management systems. In addition to replacing artificial metering, it can also support a variety of different electricity rates, provides user energy use information, and has energy saving of users spontaneously energy saving. , Discontinue power rehabilitation management, meter equipment asset management and other advantages. According to the development requirements of the domestic data acquisition and processing system and the needs of the power industry's demand -side management, Zhejiang Risesun Science and Technology Co., Ltd. relying on the strong R & D strength of the group company, it has developed a low -voltage power line carrier and automatic metering system. The operation of 100,000 carriers proves that the system has been collected stable and reliable, and the success rate of metering has reached more than 99%. The system realizes remote collection through the low -voltage power line carrier wave. The meter data is concentrated through the electrical carrier to receive the data concentrator under each transformer, and the concentrator is passed to the computer control center through the wireless network, telephone network, GPRS, CDMA and other methods. This collection method does not need to laid the line to the concentrator, and directly use the power line to do the data transmission carrier, saving costs, which is very suitable for the meter transformation of the old community.

In the mechanical structure design of the meter, as illustrated in Fig1 and Fig 2, before the design of the mechanical structure, it is necessary to determine the structure window of the main case. These components must be corresponding to the structural design specifications of the plastic parts in the mechanical manual. It is also necessary to consider the layout of the thimble of the injection mold and opening mold during the mold opening process. And satisfying the function, regardless of the convenience of desertoring, resulting in a large number of model opening production process, it is difficult to remove the rate of waste. When the design of the main case is designed, the wall thickness is generally 1.5 to 3 mm. In a place where the intensity needs to be enhanced, the bone position is needed to strengthen the bone position. At the same time, the mold is considered. You need to use a slider on the side. You need to pay special attention to whether the slider is interfered with the direction of the main case in the mold design process. In the process of the design of the mechanical structure Synchronous tops and other methods can not only be able to facilitate the design of mold design, but also meet the structural design of the main shell to meet functional design.

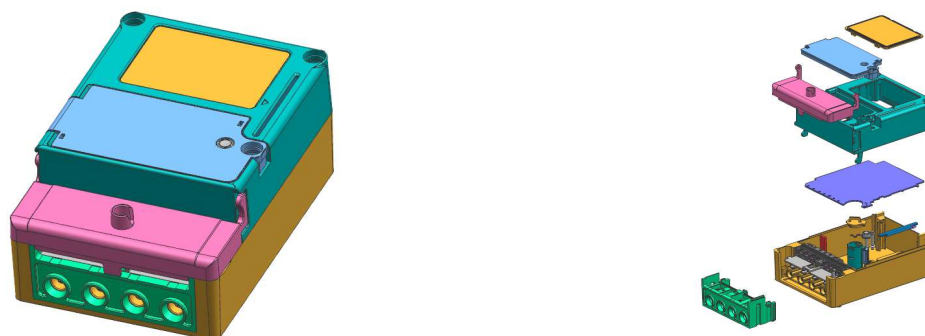

(a) Smart electricity meter assembly model (b) Smart electricity meter model Explosion

Fig. 1 Smart electricity meter structure overview

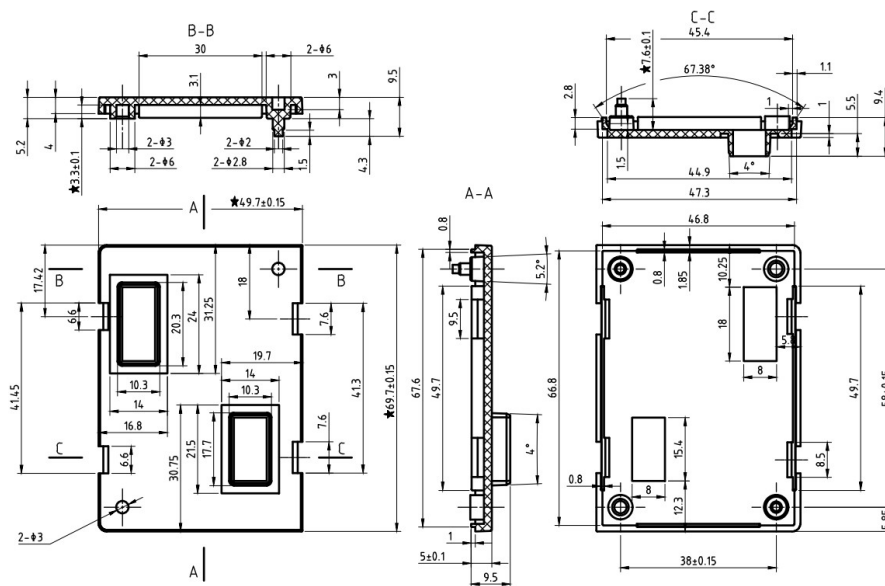

Fig. 2 meter carrier box engineering drawing

2.1. Mechanical Structure Design

Structural design of key components of smart electricity meters. Reasonably divide the shell and internal support structure of low-energy computer to ensure that the meter structure can reasonably carry the installation, fixation, maintenance, and data line insertion and removal of relevant electrical components and interface standard parts to ensure structural strength and structural stability. The key role of supporting the skeleton internally. Externally realize the shell protection of the entire meter, prevent mechanical collision, and protect internal components. At the same time, leave enough openings to ensure the plugging, unplugging and maintenance of cables, data cables, communication ports and other components. Structural design is the key to the design of key components of smart meters.

Rapid prototyping trial production of key components. Due to the complexity of the mechanical structure of the meter, certain molding defects may occur during rapid printing and molding. How to reasonably set up the printing molding process to ensure that samples can be made quickly without affecting the structure is the key to the rapid prototyping process. In the process of rapid prototyping, the design of molding materials, molding temperature and molding auxiliary structure, especially the design of auxiliary supports and the removal after molding, have a great influence on the structural strength and appearance of key components. Obtain the product requirements of mechanical structure, the molding process support and the appearance of parts. The knowledge and skills of traditional mold design and mold fitter will play an important role in the development and design of smart meters, a new type of mechanical and electrical products.

2.2. Electrical Structure Design

How single-phase smart meters work. Brief description of working principle This product is composed of metering chip, high-speed data processor, real-time clock, data interface and other equipment. Under the control of the high-speed data processor, the real-time parameters of the power grid operation are accurately obtained through the metering chip, and the data is processed according to the corresponding rate and other requirements, and the results are saved in the data memory, and the external interface is provided with information and data exchange at any time.

The billing function is mainly completed by the long -range main station/electricity sales system. The power meter receives the pull gate issued by the remote electricity sales system,

allows the gates, and the ESAM data to copy the instructions. The data interaction process must pass strict password verification and security certification and its filing documents. When the user is in arrears, the remote main station/electricity sales system will send the gates to use the household power off. When the user recharges, the remote main station/electricity sales system will send the allowable gate to order to allow the user to bind.

3. Molding Process Formulation

After designing the overall structure of the Internet of Things meter, the design of the installation accessories is equally important to the mold design of the mold. Whether it is reliable installation and whether it can not fail in the service life. For example, in the indoor climbing installation method, when the cabinet of the unit distribution box is installed, the design mechanical structure bottom cover should be fully considered. The diameter and depth of the design should be considered when the design is climbing, and the ratio of the size of the waist-shaped holes should be used to simulate whether it will have stuck when the installation is installed. The design requirements are constantly clearing in the design and repeated interference simulation simulation to exclude design errors.

The structural design of the mold. The meter mechanical component is made through the destined type of mold. The quality of the mold directly determines the quality of the smart meter mechanical structure. Many of the product molding molds have not been touched by the meter structure. They may feel that the design of the smart meter mold structure is not very complicated. In fact, the mold design needs to be considered many factors. If the shape of the product is relatively simple, we can use the mold CAD software to engraved into the mold. However, if a smart meter product containing a variety of electrical components, information and communication interfaces, etc., traditional mechanical structure design and molding process may bring problems such as product defects or uneven molding. Therefore When designing the mechanical structure, some factors must be considered in the process of pouring production, such as mold flow analysis, nozzle flow rate, exhaust design, etc. If these factors are considered in the design in advance, the final designed molds are likely to cause various quality problems during product pouring, resulting in the inherent structure deviation or appearance quality of the smart meter, which affects the customer experience.

After designing the climbing, you need to consider the climbing structure on the bottom cover. In the mold opening solution of the injection molding mold, it is the sides of the ancient slider to make the core and the core. The production of the production of the production is out. When installing the installation and feed parts of the surface and the surface of the surface, you need to consider whether the copper embedded parts are pulled off to meet the standard specifications. The load of all components after the watch body is installed. Both the load and static load must be fully simulated and analyzed. Finally, the appropriate copper embedded copper pillar and copper column design should be selected. It is necessary to design the angle of the extraction during the mold design, which is convenient for the release and the copper embedded parts during the riveting heat processing processing. The remaining slope is sufficient.the concept design illustration was shown in Fig 3.

The molding mold of key components of the smart meter is mainly formed by plastic cavity and metal pressure. Generally, professional modeling and programming software must be used. The same or similar set of processing features, just make a module, can use geometric changes such as array and scaling to make several other. Correct modeling is the key to making mold intelligence. Practice tells us that the programming thinking of mold curved surface is basically the same as its modeling method. The curves and features used in the shape determine the tool path during programming. The precision processing strategy in mold intelligence requires that the road path of the empty knife is small, the execution speed is fast, the cutting trajectory is

clear and smooth, there is no approach error and the pause of the middle, as smooth as the highway. Cross intersection. The programming technique of mold intelligence is lies in the smooth transition between the processing surface and seamless connection. For complex mold surfaces composed of multiple curved surfaces, it should be continuously processed in one process as much as possible to reduce the secondary and knives of the knife and the secondary tools. Positive knife error. In the commonly used curved processing path, the streamlined knife road and three -dimensional spiral knife road are effective. These two types of knife paths can generate continuous and smooth cutting routes without raising the knife. change. Even if the tool moves a small distance, it is necessary to be coherent, advanced and backward. There are no marks on the surface of the mold on the surface of the mold and cutting into the cutter.

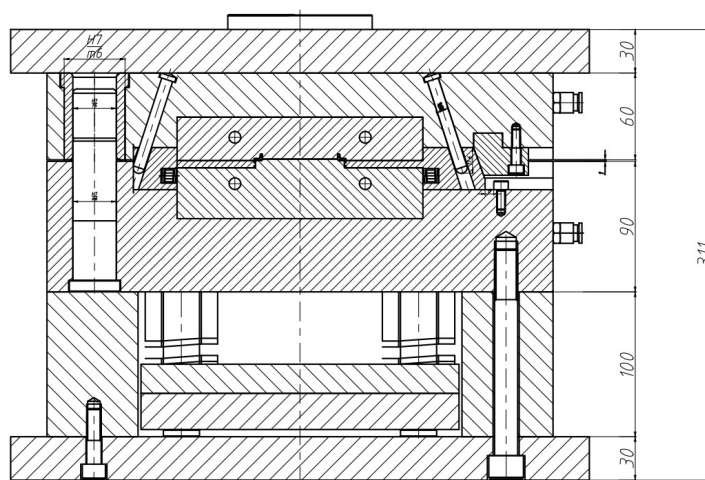

Fig. 3 View of the carrier box mold, side view

4. Model Key Technology

(1) Product modeling technology. Under the vigorous advancement of Made in China 2025, under the vigorous development of computer technology, product modeling technology has developed greatly. Three -dimensional physical modeling software will play a great role in the structural design of the smart meter. Large -scale three -dimensional software at home and abroad, such as UG, Solidworks, Zhongwang 3D under the support of computer technology, has basically realized all visible and virtual entities. Facial shape technology can make complex physical and curved shapes of various shapes and characteristics. How to focus on computer graphics, product modeling functions, beauty, color and other elements into smart meters to achieve the unity of the physical function and decoration of the meter meter, and obtain the double harvest of product electromechanical, information functions and appearance shapes. One of the key technologies. In fact, industrial product modeling technology is a very important technology. In relevant colleges and universities, even the four -year undergraduate major or product design of industrial design for three -year high vocational majors. For mechanical engineering -related majors, the shape of a smart meter with high quality can achieve the unity of machinery, electrical, information, and aesthetic appearance, and obtain the double harvest of mechanical related teachers and students' engineering technology and art aesthetics.

(2) Quick molding technology. For the iterative upgrade of existing products or the development and development of new models of products, the project quickly produces corresponding supporting key components based on the shape and process of target product models. This can shorten the formation cycle of the new model of products, reduce development costs, and shorten the trial time of smart meter model upgrades or new product development. Thanks to the efficiency of three -dimensional printing technology, which can not

only print hard plastic such as PLA and ABS, but also printed elastic plastic such as TPU. By printing the elastic module with a reasonable transmission coordination, it can reduce the trivial steps of the traditional hard module to add elastic transition materials to make it more stable. In addition, it can also be printed with a firing of a fir, replacing the traditional and rigid plastic suction cups, making the assembly of the shell and other accessories more stable and reliable. The smart meter will be integrated with our lives, and the smart ecological chain will continue to define people's lives.

(3) Mass production and forming technology. After repeated experiment adjustments through product structure design and fast -forming trial production, the structure and functions of the smart meter model were finally determined. Large quantitative production of smart meters is generally implemented by mold molding. Its mold structure generally has inlaid components, which is to facilitate the release of products in the mold cavity. The surface of the meter box is uneven and has an irregular shape. The structure design of the meter box mold is limited. It requires the design of the inner cavity to not destroy the mold infrastructure, so in a limited condition, we can make up for this defect through the inlaid components. In fact, not all the meter box molds need to be inlaid well every time they produce. Some inlaid use active design, and the product will not fall out when the product is released. The next time operator pour plastic, operator only need to squeeze the inlaid into the mold through the mold when the mold is used to reset the mold. This squeezing reset eliminates manual and tedious reset operations when the traditional mold opening is available, reducing the number of personnel work tasks, but the premise must be the direct contact surface of the inlaid of the meter box mold and the front mold. The meter box mold structure with activity inlaid structure is relatively flexible. Because it is the squeezing effect of the anterior membrane when the mold is used, the corresponding front mold wear will also be accelerated. Abrasion resistance. At present, this mold on the market generally uses the method of increasing the inner wall thickness of the mold to achieve a better wear -resistant effect.

5. Conclusion

The design and molding process of the mechanical structure with the smart electricity meter with the function of the Internet of Things is very important for its large -scale production, and even an essential key production process. The interactive functions of the electric meter supported by the good structural design of the smart meter can meet the demand of the domestic power system for the collection of the Internet of Things. In the regular work, mechanical structure personnel also need to actively collect the actual engineering cases of the Internet of Things meters in domestic or foreign advanced mechanical structure design, and mechanical structure designers can also learn more about cutting -edge knowledge. This can adapt to the new era of technology brought about by technology in the new era of technology, and promotes the Internet of Things meters to play a good value and role in the new era of technology in the new era of technology. Under intelligent manufacturing conditions, the design of key parts and mould molding process are the core skills that each productive enterprise must master. Due to the high degree of technical integration and high technical content of smart meters, Zhejiang Risesun Science and Technology Co., Ltd as a national high -tech enterprise and a national demonstration higher vocational college in Wenzhou Polytechnic to carry out the design and development of key components of smart electricity meters made a reality significance for society and industry.

Acknowledgments

This paper is a phased research result of the scientific research project of Zhejiang Provincial Department of Education 2020 University Visiting Engineer "College-Enterprise Cooperation

Projects"(Project No. FG2020059, project name"Smart electricity meter key component design and molding process development").The Author would like to express greatly gratitude for the supports from all the related organization, the relevant enterprise and the colleague and friends inside or outside the college.

References

- [1] Nguyen, Pettersen S . Mobile application for household energy consumption feedback using smart meters: Increasing energy awareness, encouraging energy savings and avoiding energy peaks[C] International Conference on Collaboration Technologies & Systems. IEEE, 2014:291-296.
- [2] Alahakoon D , Yu X . Smart Electricity Meter Data Intelligence for Future Energy Systems: A Survey[J]. IEEE Transactions on Industrial Informatics, 2016, 12(1):425-436.
- [3] Hopf K , Sodenkamp M , Kozlovkiy I , et al. Feature extraction and filtering for household classification based on smart electricity meter data[J]. Computer Science - Research and Development, 2016, 31(3pt.2):141-148.
- [4] Costa N , Matos I . Inferring daily routines from electricity meter data[J]. Energy & Buildings, 2016, 110(JAN.):294-301.
- [5] Xu D , Wei Q , Elsayed E A , et al. Multivariate Degradation Modeling of Smart Electricity Meter with Multiple Performance Characteristics via Vine Copulas[J]. Quality & Reliability Engineering International, 2017, 33(4):803-821.
- [6] Dent I , Craig T , Aickelin U , et al. A Method for Evaluating Options for Motif Detection in Electricity Meter Data[J]. Journal of Data Science, 2018, 16(1):1-28.
- [7] Zhou Z . Design and Implementation about Secure Smart Electricity Meter Sealing Based on RF Tag[J]. International Journal of Security & Its Applications, 2015, 9(6):79-88.
- [8] Marais Z , Brom H , Kok G , et al. Reduction of Static Electricity Meter Errors by Broadband Compensation of Voltage and Current Channel Differences[J]. IEEE Transactions on Instrumentation and Measurement, 2020, PP(99):1-1.
- [9] Godec D , Brnadi V , Breki T . Optimisation of Mould Design for Injection Moulding – Numerical Approach[J]. Tehnički Glasnik, 2021, 15(2):258-266.
- [10] Sheng Q , Huang L , Wang X , et al. Research and Analysis on Evaluation Methods of Electrical Performance of Smart Energy Meters[J]. Journal of Physics: Conference Series, 2021, 1802(3):032 135 (8pp).