

# Application of ZigBee Technology in Smart Soil Temperature and Humidity Control Systems

Xiaolei Zhong<sup>1</sup>, Rui Qiao<sup>2,3,\*</sup>, and Xin Wang<sup>4,5</sup>

<sup>1</sup> Dianchi College, Kunming 650228, China

<sup>2</sup> School of computer science and technology, Wuhan University of Science and Technology  
Wuhan 430065, China

<sup>3</sup> Hubei Province Key Laboratory of Intelligent Information Processing and Real-time  
Industrial System, Wuhan 430065, China

<sup>4</sup> Yunnan College of Business Management, Anning 650301, China

<sup>5</sup> Huazhong University of Science and Technology, Wuhan 430074, China

\*Corresponding Author: Rui Qiao

## Abstract

As global food security increasingly becomes a focus, challenges faced by Chinese agriculture are particularly prominent. This study introduces an intelligent monitoring and control system for soil temperature and humidity using ZigBee technology, aimed at enhancing agricultural production efficiency and crop yield. The system's core, equipped with an STC89C52 microcontroller and DHT11 temperature and humidity sensors, gathers data and wirelessly transmits it to a central control unit via ZigBee modules, which then automatically adjusts the agricultural production environment to ensure crops grow in the most ideal soil temperature and humidity conditions. Compared to traditional methods, this system achieves remote monitoring and precise control, providing an innovative solution for modern agricultural production. Experiments prove that the system not only improves control accuracy but also significantly enhances operational convenience and response speed, playing an important role in promoting the development of smart agriculture.

## Keywords

Smart Agriculture; ZigBee Technology; Soil Temperature and Humidity Monitoring; Automatic Control.

## 1. Introduction

With the rapid progress of technology, Chinese agricultural production is gradually moving towards smart agriculture, aimed at addressing issues of low efficiency and inadequate resource utilization in traditional farming[2]. Based on ZigBee technology, this study has developed an intelligent control system for soil temperature and humidity, which realizes precise adjustment of agricultural environmental factors through automation. Compared to traditional manual observation and adjustment, this system offers a more efficient and accurate solution, making remote monitoring and real-time response possible. The implementation of the system not only optimizes the soil environment but also provides data support for agricultural production, thereby enhancing crop yield and quality, laying the foundation for the realization of intelligent and efficient agricultural production.

## 2. Overall System Scheme and Key Technologies

### 2.1. Overall System Scheme

The design of this soil temperature and humidity intelligent control system is primarily composed of lower and upper machine components. The lower machine mainly includes temperature and humidity collection circuits, relay control circuits, ZigBee wireless transmission modules, and a microcontroller system, accomplishing real-time monitoring and basic control of soil environmental parameters[3-4]. The upper machine, centered around the microcontroller system and assisted by ZigBee wireless transmission modules, LCD display, LED status indicators, and control buttons, is responsible for command issuing, data display, and user interaction. This design ensures precise control over soil temperature and humidity, as depicted in the figure 1 below.

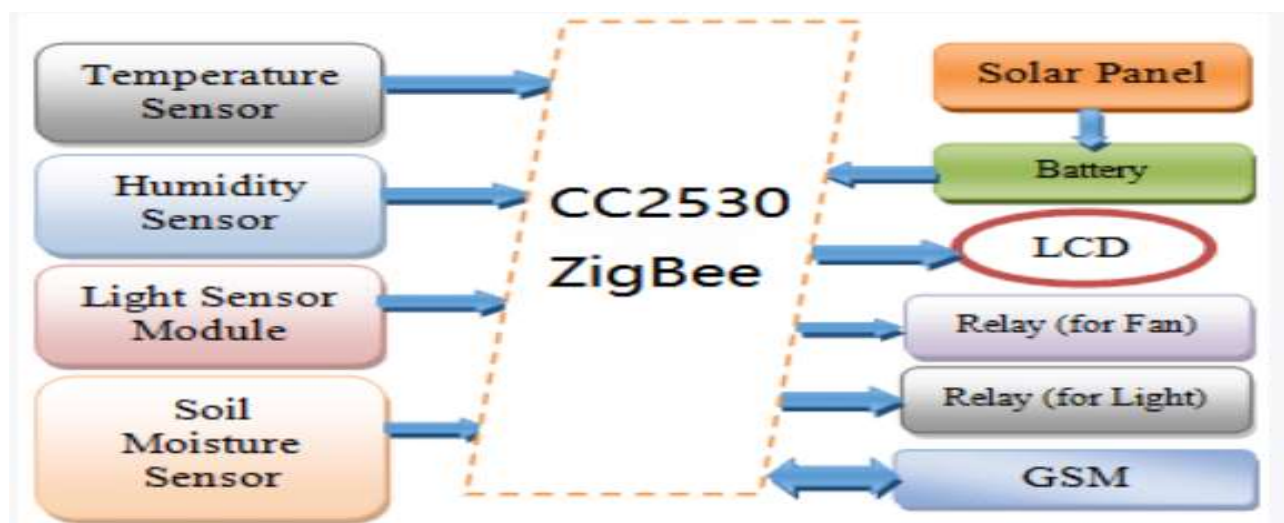

**Figure 1.** Overall Scheme of the Soil Temperature and Humidity Control System

**Hardware Architecture of the Soil Temperature and Humidity Control System:** Centered around the logical processing core of the microcontroller, this system deftly captures and processes external parameters. With the aid of AD software for circuit design and ZigBee modules for wireless data transmission, the lower machine drives the actuators according to pre-set programs to adjust the soil environment.

**Software Architecture of the Soil Temperature and Humidity Control System:** Serving as the brain of the system, the software, written in C language, enables intelligent decision-making based on feedback data. Once compiled, the code is loaded into the microcontroller, remaining intact even after power loss, facilitating system debugging and application.

### 2.2. Key Technologies

#### 2.2.1. ZigBee Wireless Communication Technology

Based on the IEEE802.15.4 standard, ZigBee technology, with its low power consumption, low cost, and high reliability features, offers a comprehensive two-way wireless communication solution[5]. Its protocol stack, following the open systems interconnection model, encompasses four layers: physical, data link, network, and application. ZigBee's self-organizing network, multi-hop routing, anti-interference, and self-recovery characteristics make it an ideal choice for this project's soil temperature and humidity monitoring research.

### 2.2.2. Data Processing Technology

The importance of data processing technology in precisely controlling soil temperature and humidity cannot be overstated. The system's adopted sliding average filter effectively removes noise, and, combined with a threshold judgment mechanism, ensures accurate data analysis and responsive system actions.

### 2.2.3. Control Technology

Control technology is at the core of this system, employing advanced PID control algorithms and fuzzy control strategies for accurate and adaptive adjustment to soil temperature and humidity changes, meeting the system's rapid response needs amidst complex environmental variations.

### 2.2.4. Human-Machine Interaction Technology

To enhance user experience and system interaction convenience, the system incorporates a human-machine interaction scheme based on graphical interfaces and touch screen technology[6]. By presenting data and control decisions through an intuitive graphic interface and facilitating swift operations via touch screen, it significantly improves operational efficiency and accuracy.

In summary, this soil temperature and humidity control system integrates key technologies such as ZigBee wireless communication, data processing, control techniques, and human-machine interaction, aiming to achieve precise environmental adjustment and efficient user interaction, demonstrating considerable application potential and innovative value.

## 3. System Design

### 3.1. Hardware Design

#### 3.1.1. Lower Machine Hardware Design

The lower machine hardware mainly includes a temperature and humidity collection circuit, a relay control circuit, a Zigbee transmission circuit, and a microcontroller system. The temperature and humidity collection circuit uses the DHT11 sensor, which is known for its high precision, stability, and low cost. The relay control circuit uses a four-channel relay module to control devices such as water pumps, dehumidifiers, heaters, and cooling units. The Zigbee transmission circuit employs the CC2530 chip, noted for its low power consumption, high reliability, and strong interference resistance. The microcontroller system uses the STC89C52 microcontroller, which offers high performance, low power consumption, and low cost.

#### 3.1.2. Upper Machine Hardware Design

The upper machine hardware mainly includes a microcontroller system, Zigbee transmission circuit, LCD display circuit, LED indicator circuit, and control buttons. The microcontroller system utilizes the STC89C52 microcontroller, identical to the lower machine. The Zigbee transmission circuit also employs the CC2530 chip, matching the lower machine's transmission circuit. The LCD display circuit uses a 1602 LCD screen to display temperature and humidity data and control status. The LED indicator circuit features two LEDs to indicate the communication and control status between the upper and lower machines. The control buttons, consisting of four keys, are used for human-machine interaction control.

### 3.2. Software Design

#### 3.2.1. Lower Machine Software Design

The lower machine software mainly includes initialization module, data collection module, data processing module, data transmission module, and control module. The initialization module is responsible for initializing the microcontroller, sensor, and Zigbee module. The data collection module collects temperature and humidity data from the DHT11 sensor. The data processing

module handles the collected data, including filtering and averaging. The data transmission module transmits processed data to the upper machine via the Zigbee module. The control module controls the relay module based on commands from the upper machine, thereby controlling devices like water pumps, dehumidifiers, heaters, and cooling units.

### **3.2.2. Upper Machine Software Design**

The upper machine software primarily includes initialization module, data reception module, data display module, control module, and human-machine interaction module. The initialization module initializes the microcontroller, Zigbee module, and LCD screen. The data reception module receives temperature and humidity data from the lower machine. The data display module shows the data on the LCD screen. The control module controls the lower machine's control module based on commands from the human-machine interaction module, thereby controlling devices such as water pumps, dehumidifiers, heaters, and cooling units. The human-machine interaction module facilitates interaction with the user, including displaying current temperature and humidity data, control status, and button operations.

## **4. System Integration and Debugging**

System integration and debugging comprise both hardware and software parts for the lower and upper machines. Hardware integration and debugging primarily involve integrating and debugging the hardware of the lower and upper machines. Software integration and debugging mainly consist of integrating and debugging the software of the lower and upper machines. Throughout the integration and debugging process, functional, performance, and stability tests are necessary to ensure the system operates correctly.

### **4.1. System Software and Hardware Integration**

According to the system design scheme, the soil temperature and humidity control system software and hardware integration work has been completed. First, the temperature and humidity collection circuit, relay control circuit, zigbee transmission circuit, and single-chip microcomputer minimum system of the lower computer were connected in hardware. Then, the single-chip microcomputer minimum system, zigbee transmission circuit, LCD display circuit, LED indicator light circuit, and control button of the upper computer were connected in hardware. Then, the program of the lower computer and the upper computer was programmed and burned into the single-chip microcomputer. Finally, the lower computer and the upper computer were connected in hardware to complete the software and hardware integration of the system.

### **4.2. System Testing**

In order to verify whether the function of the soil temperature and humidity control system meets the design requirements, system testing was carried out. During the test, the lower computer was first placed in the soil that needed to be controlled, and then the upper computer was turned on to observe whether the LCD display screen could display the correct temperature and humidity data. Then, the temperature and humidity parameters were set through the control button to observe whether the relay of the lower computer could control according to the set parameters. During the test, multiple groups of different temperature and humidity parameters were used for testing, and the test data was recorded.

The test results are shown in Figures 2 and 3. It can be seen that the soil temperature and humidity control system can accurately display the temperature and humidity data of the soil and control according to the set parameters. During the test, the system ran stably without errors, meeting the design requirements.



Figure 2. Screenshot of soil temperature and humidity control system test 1

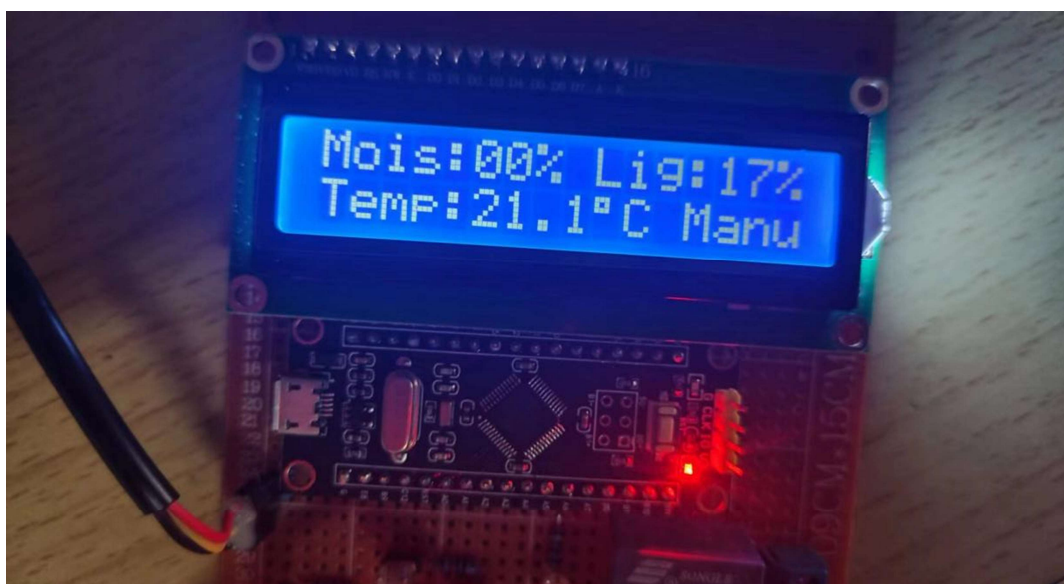

Figure 3. Screenshot of soil temperature and humidity control system test 2

### 4.3. System Application

The soil temperature and humidity control system can be widely used in agricultural production, such as farmland, flower planting, plant processing, and other fields. By monitoring and controlling the soil temperature and humidity in real-time, the quality and yield of crops can be improved, waste can be reduced during production, and fine management of agricultural production can be realized. At the same time, this system can also be used in the cultivation and maintenance of home flowers. By monitoring and controlling the soil temperature and humidity in real-time, flowers can grow in the most suitable growth environment, improving the quality and growth speed of flowers.

In summary, the soil temperature and humidity control system is a highly efficient and precise agricultural production tool with broad application prospects. By monitoring and controlling the soil temperature and humidity in real-time, fine management of agricultural production can be realized, the quality and yield of crops can be improved, and sustainable development of agricultural production can be achieved.

## 5. Conclusion

This paper presented a comprehensive system for controlling soil temperature and humidity using ZigBee communication, advanced data processing, and precise control technologies. The experimental results verified the system's effectiveness in creating optimal conditions for agricultural applications. By integrating key technologies and addressing practical challenges, the proposed system offers a valuable tool for precision farming and greenhouse management.

## Acknowledgments

This work was supported by the National Nature Science Foundation of China (grant no. 61461053, 61461054).

## References

- [1] J. F. Cheng, D. Z. Sun, C. W. Wei, et al. Soil moisture collection and control device based on single-chip microcomputer, *Agricultural Engineering Technology*, vol. 41, no. 9, pp. 50-58, 2021.
- [2] X. X. Zhou. Design of intelligent irrigation system for soil moisture control based on CMOS single-chip microcomputer, *Computer Knowledge and Technology: Academic Edition*, vol. 18, no. 30, pp. 30-36, 2022.
- [3] J. Y. Huang. Design of automatic irrigation system based on single-chip microcomputer, *Electronic World*, vol. 2021, no. 12, pp. 38-45.
- [4] Z. H. Zhang, X. Y. Li, L. J. Zhang, et al. Design research of multi-variable environmental control system for plant factory based on Android mobile phone, *Agriculture and Technology*, vol. 2023, no. 22, pp. 30-35.
- [5] J. Zhang, B. Wu. Application and effect of agricultural Internet of Things technology in facility vegetable production, *Shanghai Vegetables*, vol. 2023, no. 4, pp. 84-88.
- [6] W. Huang. Design and implementation of intelligent greenhouse system based on LoRa, *Computer and Communications*, vol. 2020, no. 9, pp. 22-28.