

# Analysis and Discussion on Self-Cleaning of Static Cone Penetrating Machine

Qilong Zhang, Haojie Mu

Zenith Steel Group Company Limited (Nantong), Nantong, Jiangsu 226000, China

---

## Abstract

Static cone penetration testing machine is a device for in-situ testing of soil parameters in foundations. During use, the surface of the probe rod is covered with soil, which affects its performance. This article proposes a self-cleaning static cone penetration testing machine. When the hydraulic cylinder drives the probe rod to move upward, the positioning plate is moved to place it on top of the upper cover plate. Furthermore, the probe first passes through a circular pipe close to the soil layer. The circular pipe sprays water evenly onto the surface of the probe through a high-pressure nozzle, and then flushes the surface of the probe to remove some soil. Then the outer wall of the probe comes into contact with the cleaning sponge through the cleaning hole, and the cleaning sponge rubs against the surface of the probe to remove a part of the soil on the surface of the probe. Finally, the probe passes through another annular tube, which sprays water evenly onto the surface of the probe through a high-pressure nozzle, and then performs a secondary flushing to clean the soil on the surface of the probe. Reducing the situation where soil adheres to the probe rod for a long time and causes corrosion, achieving the effect of easy cleaning of the soil on the surface of the probe rod.

## Keywords

Static Cone Penetration Testing Machine; Probe Rod; Self-Cleaning; Anticorrosive.

---

## 1. Introduction

Static cone penetration testing machine is an equipment for in-situ testing of soil parameters of foundation [1]. It uses a pressure device to insert a cone penetration rod with a contact probe into the test soil layer, obtain the penetration resistance of the soil layer, and then analyze and process the physical parameters of the soil layer based on the obtained penetration resistance [2].

Its working principle is to use hydraulic or mechanical devices to push the probe into the soil at a constant speed, and the sensors inside the probe record real-time data such as cone resistance and sidewall friction. These data can reflect the strength, compressibility and other characteristics of soil layers, providing important basis for engineering design and construction [3].

The static cone penetration testing machine has the advantages of easy operation, fast testing speed, and accurate data. It is widely used in construction, road, bridge and other engineering fields to help engineers understand the underground soil conditions and ensure the safety and stability of the project[3].

## 2. Static Cone Penetration Testing Machine Probe Self-Cleaning Device

The self-cleaning static cone penetration tester proposed in this article, as shown in Figures 1 to 3, includes a set of hydraulic cylinders. A lower transverse plate is horizontally installed between the hydraulic rods, and the end wall of the lower transverse plate is welded to the side wall of the hydraulic cylinder. The hydraulic rod of the hydraulic cylinder is arranged along the height direction,

and a horizontal plate is welded to the hydraulic rod. The upper horizontal plate is located directly above the lower horizontal plate and is horizontally arranged. Install a probe along the height direction at the center of the bottom of the upper horizontal plate, with one end of the probe welded to the bottom of the upper horizontal plate and the other end penetrating the lower horizontal plate. Install a set of circular pipes directly below the lower horizontal plate, with the circular pipes horizontally arranged. One circular pipe is located directly above the other, and the inner side of the circular pipe is used for inserting probe rods. Several high-pressure nozzles are installed on the inner side of the annular tube, and the high-pressure nozzles are evenly distributed. Install a water supply component on the circular pipe, which is used to supply water to the inside of the circular pipe. Install cleaning sponge between the circular pipes, and the cleaning surface is made of sponge material. The cleaning sponge is located directly below one of the circular tubes and directly above the other circular tube. A cleaning hole is opened along the height direction on the cleaning sponge, which is used for inserting a probe rod. Install connecting components at the bottom of the lower horizontal plate, which are used to connect the annular pipe, cleaning sponge, and lower horizontal plate. The hydraulic cylinder is activated, and the hydraulic rod of the hydraulic cylinder drives the upper horizontal plate to move downwards. The movement of the upper horizontal plate drives the probe rod to move downwards and be inserted into the soil layer. When the hydraulic cylinder drives the probe rod to move upward, the water supply component first supplies water to the annular pipe near the soil layer. The annular pipe sprays water evenly onto the surface of the probe rod through a high-pressure nozzle, and then flushes the surface of the probe rod to remove some soil. Then the outer wall of the probe comes into contact with the cleaning sponge through the cleaning hole, and the cleaning sponge rubs against the surface of the probe to remove a part of the soil on the surface of the probe. Finally, the probe passes through another annular tube, which sprays water evenly onto the surface of the probe through a high-pressure nozzle, and then performs a secondary flushing to clean the soil on the surface of the probe.

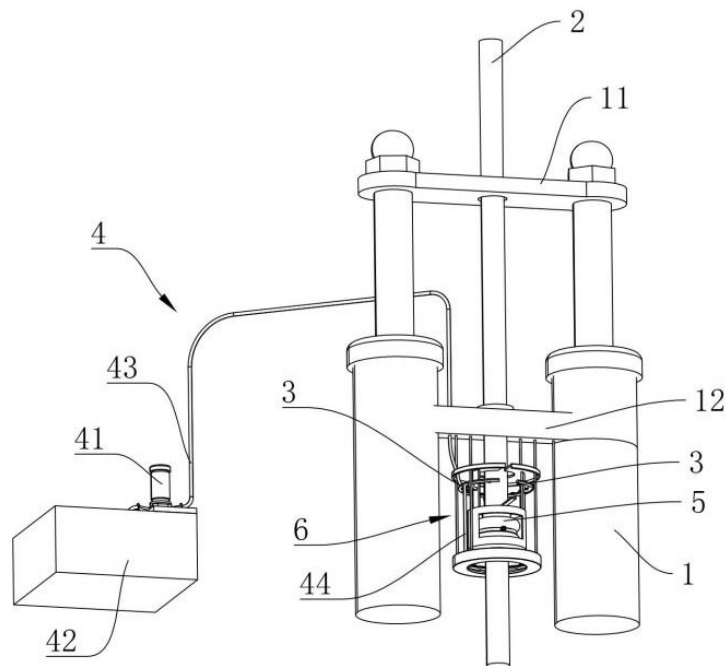

**Figure 1.** is a schematic diagram of the structure of a self-cleaning static cone penetration tester

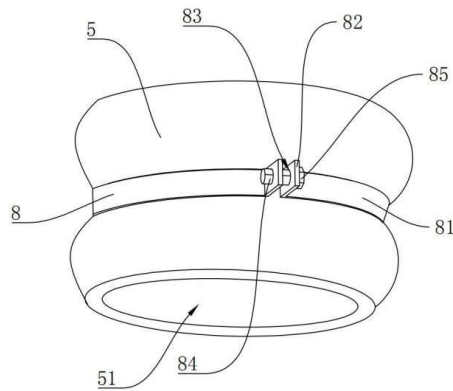

**Figure 2.** is a schematic diagram of the structure of the cleaning cotton

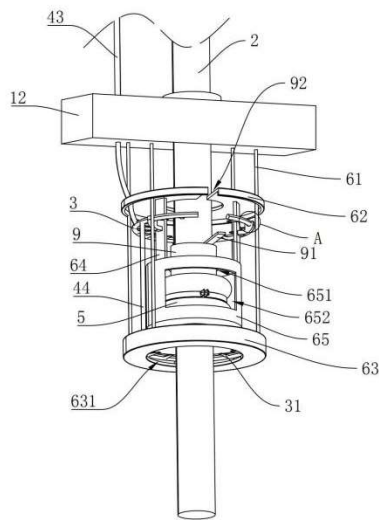

**Figure 3.** is a schematic diagram of the connection between the annular tube and the high-pressure nozzle

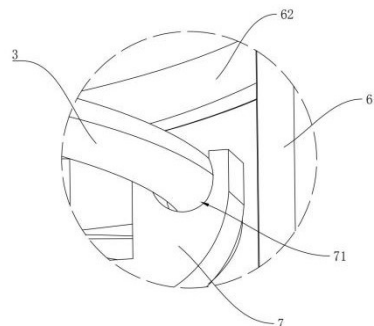

**Figure 4.** is an enlarged view of part A in Figure 3

Annotations on accompanying drawings: 1. Hydraulic cylinder; 11. Upper horizontal board; 12. Lower horizontal board; 2. Probe rod; 3. Circular tube; 31. High pressure nozzle; 4. Water supply components; 41. Water supply pump; 42. Water supply tank; 43. Water supply pipe one; 44. Water

supply pipe 2; 5. Cleaning sponge; 51. Clean the hole; 6. Connecting components; 61. Support rod; 62. Upper cover plate; 63. Lower cover plate; 631. Make way for the hole; 64. Connection board; 65. Connecting cylinder; 651. Insertion hole; 652. Take out the hole; 7. Card block; 71. Card slot; 8. Tighten the half ring one; 81. Tighten half ring two; 82. Tighten the plate; 83. Tighten the hole; 84. Tighten the bolts; 85. Tighten the nut; 9. Guiding cylinder; 91. Positioning board; 92. Positioning hole.

In order to achieve the effect of supplying water into the annular pipe, referring to Figures 1 and 3, the water supply component includes a water supply tank, a water supply pump, water supply pipe one, and water supply pipe two. The inlet of the water supply pump is connected to the water supply tank, the outlet of the water supply pump is connected to one end of the water supply pipe, and the other end of the water supply pipe is connected to the annular pipe near the lower horizontal plate. The two water supply pipes are arranged along the height direction, and one end of the two water supply pipes is connected to each other in a circular shape, while the other end of the water supply pipe is connected to the other circular shape. The water supply pump is started, and the water in the water supply tank is moved into the water supply pipe through the water supply pump. Water supply pipe one moves the water into the circular pipe near the lower horizontal plate, and the water in the upper circular pipe moves into the lower circular pipe through water supply pipe two. Thereby achieving the effect of supplying water into the annular pipe.

For easy cleaning of the cotton cleaning probe, refer to Figure 2 and Figure 3 to open a removal hole on the connecting cylinder wall. Install the tightening half ring 1 and tightening half ring 2 symmetrically on the outside of the cleaning cotton. Tighten half ring 1 is connected to one end of tightening half ring 2 by rotating, and the other end of tightening half ring 1 is welded with a receiving plate on the other end of tightening half ring 2. Tighten the half ring with a tightening bolt and a tightening nut on the tightening bolt. A tightening hole is opened on the tightening plate, and the tightening bolt passes through the tightening hole and is connected to the tightening bolt thread.

In order to facilitate the insertion of the probe into the cleaning hole, refer to Figure 3. A guide cylinder is set up for sliding in the cleaning hole, and the guide hole is used for the insertion of the probe. The diameter of the guide cylinder near the lower cover plate is smaller than the diameter of the guide cylinder near the upper cover plate. Install a set of positioning plates on the top wall of the guide cylinder, set horizontally, and weld the bottom wall of the positioning plate to the top of the guide cylinder. A set of positioning holes are opened on the upper cover plate for inserting the positioning plate.

### 3. Conclusion

The self-cleaning static cone penetration tester proposed in this article achieves the effect of easy cleaning of the surface soil of the probe rod through the setting of hydraulic cylinder, lower transverse plate, upper transverse plate, probe rod, annular tube, high-pressure nozzle, cleaning sponge, cleaning hole, water supply component and connecting component, reducing the situation of soil adhering to the probe rod for a long time and causing corrosion of the probe rod.

### References

- [1] Wu Daoxiang, Dan Cancan, Zhong Xuanming, et al. Development of Static Cone Penetration Testing and Its Application in Geotechnical Engineering [J]. Journal of Hefei University of Technology (Natural Science Edition). 2008.
- [2] Liu Songyu, Wu Yankai. On the Current Status and Development of Static Cone Penetration Testing (CPT) Technology in China [J]. Journal of Geotechnical Engineering, 2004.
- [3] Wang Zhongqi. Development prospects of static and dynamic cone penetration tests in China [J]. Journal of Geotechnical Engineering. 2000.
- [4] Tang Xianqiang, Ye Qimin. Static Cone Penetration Test [M]. China Railway Press, 1981.