

A Survey of Multi-agent Systems based on Large Language Models

Chengze Deng, Shixing Li

North Automatic Control Technology Institute, Taiyuan 030006, China

Abstract

Traditional MAS demonstrate significant limitations in handling dynamic environments and generalization capabilities. The emergence of LLM, however, has revolutionized the development of MAS through their ability to enhance individual agents' cognitive capacities while significantly improving inter-agent collaboration. This paper systematically examines the architecture and components of LLM-based MAS, detailing the collaborative mechanisms and communication frameworks. It concludes with an analysis of typical applications and current faced challenges, including insufficient decision-making interpretability and the lack of effective evaluation methodologies.

Keywords

Multi-Agent Systems(MAS); Large Language Models(LLM); Collaboration Models; Communication Module.

1. Introduction

MAS is a distributed system[1] composed of multiple autonomous agents[2-4]. Each agent can independently perceive the environment, learn and make decisions to achieve its own goals or complete the overall goal cooperatively[5-6]. It is the core research direction of distributed artificial intelligence.

Traditional MAS is built on three foundational theories: game theory, reinforcement learning, and distributed computing. These frameworks enable such systems to demonstrate basic capabilities in strategy selection, learning, communication, coordination, and resource allocation[7-10]. However, these systems face multiple challenges: agents' decision-making is constrained by predefined rules and limited state spaces, making them hard to handle the complexities of open environments; the communication efficiency between intelligent agents is low, and there is a lack of deep semantic understanding and contextual reasoning ability; and they require extensive domain expertise with manual debugging, resulting in insufficient generalization and adaptability[11-14]. These limitations have driven researchers to seek new technological breakthroughs.

The emergence of LLM has revolutionized the development of MAS. LLM-based MAS leverage these powerful models as "brains" for intelligent agents, endowing them with robust natural language understanding, contextual reasoning, and knowledge generalization capabilities[15]. Each agent can assume specific roles, enabling efficient communication and collaboration through language interfaces, which significantly enhances system flexibility and adaptability. Moreover, LLM not only boost the cognitive abilities of individual agents but also greatly facilitate effective inter-agent collaboration by providing shared linguistic frameworks and comprehension mechanisms[16].

This paper aims to systematically review the research progress of LLM-based MAS, conducting a comprehensive analysis from aspects such as related technologies, application scenarios, and challenges. Section 2 provides a detailed introduction to the relevant technologies ; Section 3

analyzes typical application scenarios; Section 4 discusses the challenges faced; and finally, the paper concludes with an outlook on future research prospects.

2. Related Technologies of MAS

2.1. Architecture and Composition

The architecture of LLM-based MAS primarily consists of three core modules: the agent composition module, the agent interaction module, and the environment interaction module. This design not only retains the distributed characteristics of traditional MAS but also incorporates cognitive breakthroughs enabled by LLM. The core components of the MAS are detailed in Table 1.

Table 1. Components and functions of MAS

Component category	Elements	Description	Examples
Agent Composition	Character images	Define the professional domain and behavior characteristics of the agent	Engineers, product managers, doctors, etc
	Cognition and decision-making	Give the agent the ability to reason and plan	Memory management, RAG, etc
	Capacity configuration	Determine the professional skills and tool use capabilities of the agent	Code writing, data analysis, network management, etc
Environmental Interactions	Environmental perception	Receive environmental status information	Virtual environment interface, physical environment interface, etc
	Execution	Convert the agent's decision into an action	Application programming interface, etc
	Feedback mechanism	Collect feedback on agent actions	Human feedback, environmental feedback, agent feedback, etc
Multi-agent Interaction	Collaboration models	The way the agents work together and behavior management	Cooperation, competition, cooperation
	Communication module	The structure of information transmission and communication protocol management	Centralized, decentralized, hierarchical
	Content and format	The form of interactive information and prompt project	Text, code, structured data

2.1.1. LLM-based Agents

Every agent is the basic unit of the whole system. A LLM-based agent is an intelligent entity that incorporates a LLM as its core component, comprising three key elements: character images, cognition and decision-making, and capacity configuration[17]. As shown in Table 2, traditional agents differ significantly from LLM agents in their characteristics.

LLM-based agents leverage the reasoning chains and problem decomposition capabilities of LLM for inference and planning, while expanding their perception and action spaces through environmental perception and tool integration. Therefore, an LLM agent can be represented as a multi-component system $a = \{m, o, e, x, y\}$, where m denotes the LLM, o represents the objective, e indicates the environment, x stands for input perception, and y signifies output actions. A MAS

can be expressed as $S=\{A, M, E, C\}$, where A is the agent set, M denotes shared objectives, E refers to the shared environment, and C represents collaborative communication channels.

Table 2. The characteristic difference between traditional agent and LLM agent

Characteristic	Traditional Agent	LLM Agent
Response	Quickly perceive changes and respond to them according to the rules	Understand changes and respond flexibly
Initiative	Act on instructions	Think proactively and then act
Reasoning	Think in terms of fixed logic or algorithms	Understand natural language and think complex
Planning	Make plans by steps or algorithms	Understand the task and make plans flexibly
Learning and Adaptation	Learn through training	Learn and adapt quickly to new situations

2.1.2. Architecture and Workflow

In LLM-based MAS architectures, the agent interaction module coordinates collaboration and communication among multiple agents. The environment interaction module serves as the bridge connecting agents to the external environment, primarily integrating and utilizing resources through environmental perception, action execution, and feedback mechanism. Figure 1 illustrates the operational functions and interrelationships within LLM-driven MAS architectures.

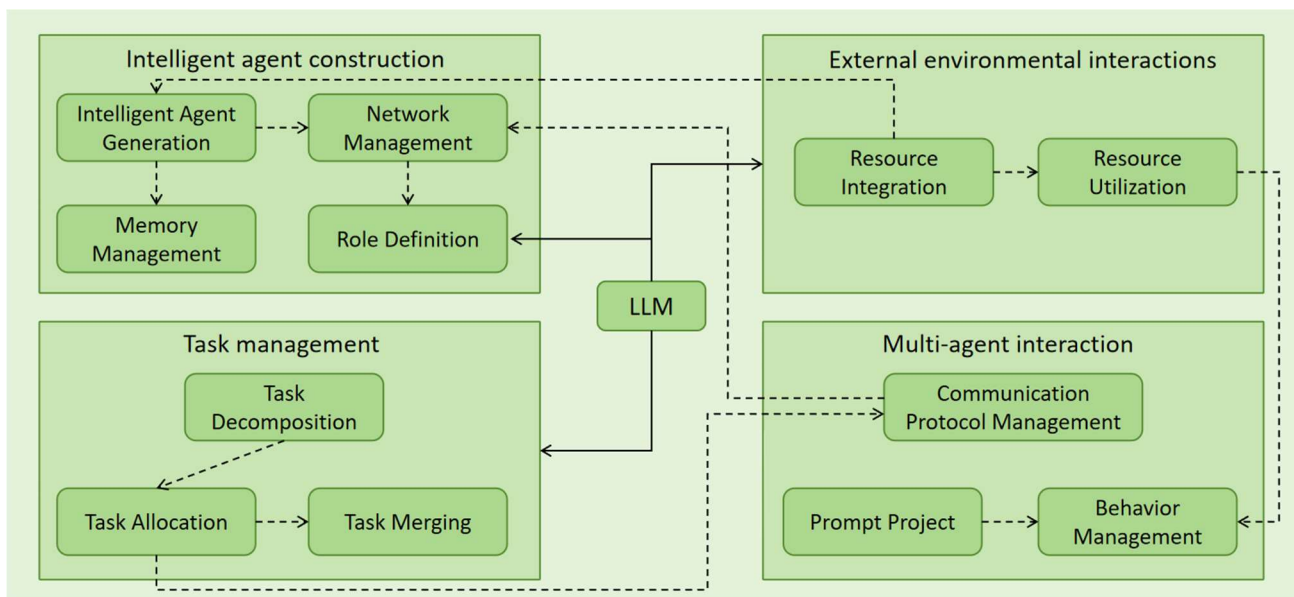

Figure 1. The operation function and interaction relationship of the multi-agent system architecture driven by large language models

In addition to the agent composition module, agent interaction module, and environmental interaction module, the framework also requires the goal-driven task management module during operation. The workflow proceeds as follows: First, users define domain objectives and functional requirements while providing external resources such as data, tools, and models. Next, the task management module and agent interaction module collaborate to coordinate multiple specialized agents in processing these external resources. Through LLM-driven analysis, they perform objective evaluation and subtask decomposition. Subsequently, the environment interaction module engages with users to establish final task objectives, followed

by comprehensive solution development through interaction with external environmental resources. Finally, the MAS generates processed results and provides feedback to users.

2.2. Collaboration Models

The collaborative models of MAS primarily include cooperation, competition, and cooperation, as illustrated in Figure 2. In the cooperation model, agents exchange information and make coordinated decisions toward shared objectives. During cooperation, agents propose and maintain diverse perspectives, ultimately reaching consensus through mutual evaluation and adjustments. In the competition model, agents have their own independent goals, which may conflict with each other, and they need to seek the balance of interests through game.

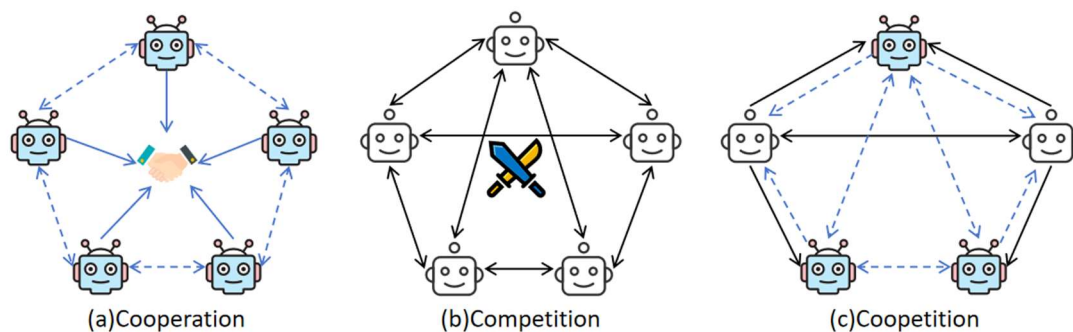

Figure 2. Collaboration model of MAS

2.2.1. Cooperation

In MAS, cooperation mode manifests as coordinated behaviors adopted by agents to achieve shared objectives. This paradigm centers on resource sharing and complementary expertise, where structured division of labor organically integrates individual capabilities to maximize system efficiency. Within these cooperative frameworks, interactions between agents involve proactive information exchange and dynamic coordination of decision-making processes, ultimately guiding consensus-driven collective decisions and task execution[18]. Yang Tingting et al. developed the AutoHMA-LLM innovative framework by integrating LLM with classical control algorithms. Using cloud-based LLM as central coordinator while incorporating device-specific LLM and generative agents, this approach significantly enhances task execution efficiency and accuracy[19]. Wu Xinyu et al. established an HVAC intelligent energy-saving management system integrating five core agents: knowledge Q&A, data analytics, operational management, energy optimization, and document generation, effectively achieving environmental goals of energy conservation and emission reduction[20].

The cooperation model faces multiple challenges. For instance, task coordination proves particularly difficult, requiring strategic allocation of responsibilities to prevent resource redundancy and redundant work. Furthermore, ensuring seamless information sharing within heterogeneous agent systems necessitates establishing unified data protocols and communication standards—a critical challenge currently. Additionally, the model may lead to instances where some agents contribute minimally while reaping disproportionate benefits. This inequity could result in uneven operational efficiency across agents, ultimately undermining the full potential of multi-agent collaboration.

2.2.2. Competition

Competition mode refers to the behavioral paradigm where intelligent agents compete for limited resources to achieve their independent objectives, essentially constituting a zero-sum game. In this framework, agents prioritize maximizing their own benefits, which often leads to resource hoarding and strategic conflicts, potentially degrading overall system efficiency[21]. Its inherent flaws include: resource competition causing internal friction that reduces system

performance; excessive rivalry disrupting stability and triggering system fluctuations; and susceptibility to Nash equilibrium traps like the "Prisoner's Dilemma," making it difficult for both individual and collective optimal outcomes to be achieved. However, pure competition is relatively rare in LLM-based MAS. Thanks to the inherent efficiency of LLM in natural language communication, system designs tend to adopt cooperation mode or competition mode.

2.2.3. Coopetition

Coopetition represents a hybrid model that integrates competitive and cooperative elements. Intelligent agents collaborate for mutual benefit in certain aspects while maintaining rational competition in others, achieving dynamic equilibrium between collective and individual interests. This approach proves particularly effective in complex task environments, demonstrating flexible adaptability to evolving scenario requirements. Yuan Xu et al. proposed a method based on a dual-layer LLM-based MAS, where internal voting among agents in the first layer and cross-voting between different agents in the second layer significantly improved clickbait detection accuracy[22]. The coopetition mode transcends the traditional binary opposition between cooperation and competition, enhancing task planning efficiency, reducing resource conflicts, and improving system stability and reliability when addressing challenges.

2.3. Communication Structure

The communication structure determines the relationship between agents and the way information flows. The communication structure of a MAS mainly includes three types: centralized, decentralized and hierarchical, as shown in Figure 3.

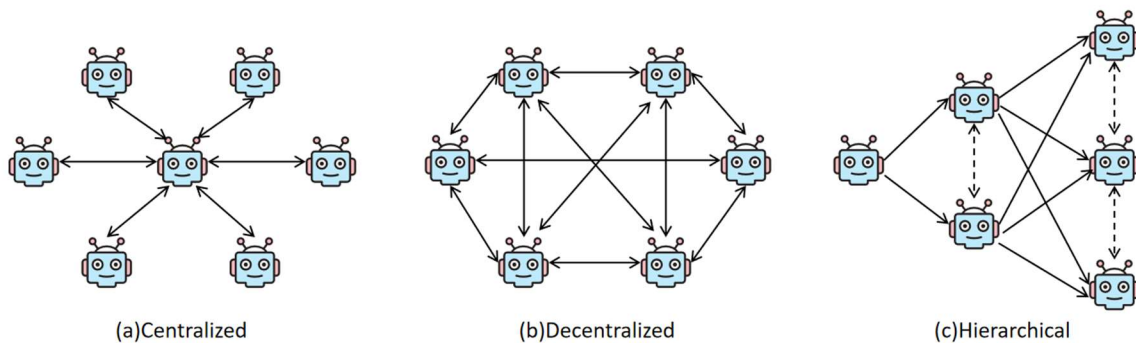

Figure 3. Communication structure of MAS

2.3.1. Centralization

Centralized architecture manages and makes decisions through a central control agent, while other agents operate as subordinate units. This central agent aggregates global information, coordinates task allocation, and allocates resources. Han Yunjun et al. have leveraged the strengths of LLM in long-chain decision-making and emergent capabilities, combined with small models' advantages in precise modeling and rapid computation, to provide more intelligent and comprehensive support for military command in time-varying environments and intelligent production services[23]. Ding Zhijian and colleagues developed a food safety legal Q&A system with administrator agents as the core hub, significantly enhancing service efficiency in legal scenarios[24]. This centralized decision-making structure features a straightforward architecture similar to single-agent extensions, enabling global optimization. However, its heavy reliance on central nodes introduces risks of single-point failures and demonstrates limited scalability.

2.3.2. Decentralized

Decentralized architecture enables peer-to-peer autonomous decision-making among all agents. Coordination is achieved through communication and negotiation, with each agent

independently acting based on local information and protocols, while collective behavior emerges through interactions. Zhang Peilong et al. proposed an LLM-driven framework for multi-agent network intent recognition, comprising four components: information processing agents, operations/product management agents, maintenance engineers, and TOSCA standard verification agents. By assigning distinct tasks to each agent, the intent recognition process becomes distributed across multiple entities. This approach allows users to more easily trace and understand the framework's logic, thereby enhancing transparency and credibility in intent identification[25]. Meanwhile, I. Chatzistefanidis et al. developed the MAESTRO collaborative framework, where coordinated resource negotiation among agents achieves consensus alignment between multi-party operations and network objectives[26].

This architecture eliminates the single-point failure bottleneck caused by central nodes, significantly enhancing scalability and robustness. The system can continue operating even when some agents fail. However, due to decentralized decision-making, maintaining consistency in communication and collaboration becomes more challenging. Therefore, it requires designing more rigorous mechanisms to better prevent conflicts[27].

2.3.3. Hierarchical

Between the above two extremes, the hierarchical structure organizes agent components into a layered framework for hierarchical control. Higher-level agents are responsible for global planning or decision-making, guiding lower-level agents to execute specific subtasks through issuing commands or setting objectives. Sun Yi and colleagues proposed a multi-cyclic nested LLM-based multi-agent command-control model. Through two "human-like" LLM agents-commander and mobilizer-they achieved text-based command-control simulation tasks using physics engines, enabling multi-dimensional system evaluation and analysis[28]. Mario De Jesus and his team developed the KubeLLM framework, a multi-agent architecture based on LLM. This framework automates Kubernetes cluster fault resolution by diagnosing configuration errors, analyzing root causes, and implementing necessary fixes[29]. This hierarchical structure maintains global coordination while preserving the autonomy and parallel processing capabilities of lower-level agents, making it widely adopted in complex systems to enhance manageability.

3. Application Scenarios

3.1. Intelligent Transformation of Physical Industries

MAS play a pivotal role in the intelligent transformation of physical industries such as manufacturing and agriculture, achieving cost reduction and efficiency enhancement through restructuring production logic and business processes. In smart factory applications, these systems integrate with digital twins to develop digital twin models for blast furnace continuous production. Industrial blast furnaces utilize a hybrid architecture combining large and small models: the foundational large model simulates physical field dynamics through multi-agent mechanism modeling, while incremental small models employ adaptive learning for real-time updates. System-level coordination among these agents ensures stable blast furnace operations[30]. In agriculture, MAS address complex farming scenarios across plowing, planting, cultivation, and harvesting phases. The intelligent data acquisition module continuously monitors environmental and crop conditions, the processing module converts data into actionable insights, while task allocation agents dynamically coordinate assignments based on these insights. Execution agents carry out specific operations, with feedback mechanisms continuously refining both decision-making processes and operational workflows[31].

3.2. Collective Decision-making

MAS achieve emergent swarm intelligence through distributed decision-making and collaborative control mechanisms in dynamic complex environments, significantly enhancing system adaptability and robustness[32]. In robotic swarm control, swarm intelligence technology is integrated with humanoid robotics, utilizing a super brain and intelligent micro-brain at the swarm level to accomplish complex tasks. The super brain leverages multi-modal embodied reasoning large models for high-dimensional decision-making in complex production line-level operations, while the intelligent micro-brain employs Transformer models to pioneer cross-domain fusion perception and multi-robot collaborative control technologies. Additionally, addressing the complexity and real-time challenges of multi-domain collaborative decision-making in large-scale dynamic operational environments, Zou Tong et al. proposed a cluster collaborative decision-making framework based on LLM. Through prompt engineering, environmental situation textification, and multi-level instruction parsing, this approach overcomes the limitations of traditional target allocation methods that only handle discrete tasks, achieving unified coordination between discrete task allocation and continuous spatial decision-making[33].

3.3. Knowledge Retrieval Questions

The integration of knowledge graphs, professional knowledge bases, and LLM-based MAS is revolutionizing knowledge retrieval and Q&A processes in specialized fields, significantly enhancing knowledge acquisition efficiency and decision-making accuracy. In enterprise operations management, combining contextual retrieval enhancement technology with MAS has created a novel maintenance framework based on LLM. Through collaboration between supervisor agents and multiple functional agents, this system utilizes core capabilities including knowledge Q&A, fault analysis, and knowledge base management to achieve rapid diagnosis and resolution of system failures, effectively improving both diagnostic accuracy and system response efficiency[34].

4. Challenges

4.1. Interpretability

LLM, constructed from deep neural networks, exhibit high internal complexity. By stacking numerous parameter layers to map features and model patterns in high-dimensional spaces, they demonstrate a pronounced "black box" nature. The highly intricate and opaque reasoning processes within these models make it difficult to establish causal relationships between inputs and outputs. In LLM-based MAS, each agent relies on the LLM for guidance. The absence of clear reasoning chains in decision-making processes makes it challenging to trace and validate the decision-making logic of individual agents.

4.2. Evaluation methodologies

LLM-based MAS face a core challenge: the absence of standardized evaluation frameworks, which severely hampers their technological advancement and practical implementation[35]. The current predicament manifests in three key aspects: First, there is a lack of standardized benchmark datasets and testing environments. Existing evaluations predominantly rely on simplified simulated scenarios that fail to accurately reflect system performance in complex industrial environments. Second, manual evaluations remain dominant, suffering from issues such as subjectivity, high costs, and inconsistent quality, which cannot meet the demands of large-scale application verification. Finally, current evaluation methods predominantly involve static testing, lacking effective measurement of systems' dynamic adaptability and continuous learning capabilities during long-term operation. Establishing a multi-dimensional, hierarchical evaluation system, along with developing domain-specific benchmark testing environments

and automated assessment tools, has become an urgent requirement to propel this technology from experimental research toward industrial maturity.

5. Conclusion

This paper reviews the research progress of LLM-based MAS. From a technical perspective, it analyzes the agent architecture centered on LLM and its perception-decision-execution workflow, explores collaborative modes such as cooperation, competition, and cooperation, and compares the impact of different communication structures on system performance. In terms of applications, LLM-based MAS has demonstrated significant value in driving industry intelligence, enhancing group decision-making, and optimizing knowledge retrieval. The paper also addresses two major challenges in this field: insufficient decision interpretability limits its application in high-risk scenarios, while the lack of evaluation methods severely hinders standardization and iterative development. Although current LLM-based MAS primarily handle simple tasks through question-answering mechanisms and remain less mature compared to traditional approaches, continuous breakthroughs in LLM technology have revealed tremendous potential. These systems are poised to evolve from solving constrained problems to efficiently and reliably addressing real-world challenges in complex dynamic environments.

References

- [1] J. Zhang, Y. Wang, Z.L. Chen, et al. Multi-agent path finding algorithm, *Journal of Zhejiang University: Engineering Science*, vol.59(2025) No.8, p.1-9.
- [2] P. Li, C.F. Chen, C.S. Yi, et al. Theories and methods of multi-agent decision under risk: a survey, *Chinese Journal of Computers*(2025), p.1-31.
- [3] B. Luo, T.M. Hu, Y.H. Zhou, et al. Survey on multi agent reinforcement learning for control and decision-making, *Acta Automatica Sinica*, vol.51(2025) No.3, p.510-539.
- [4] Z.R. Chen, Z.Y. Liu, L.P. Wan, et al. A review of multi-agent reinforcement learning theory and applications, *Pattern Recognition and Artificial Intelligence*, vol.37(2024) No.10, p.851-872.
- [5] C.Y. Shan, S.F. Li, R.Y. Qi, et al. Fast task reassignment in multi-agent system emergency fault handling, *Systems Engineering and Electronics*(2025), p.1-18.
- [6] J.H. Qin, L.C. Ma, M. Li, et al. Recent advances on multi-agent collaboration: A cross-perspective of game and control theory, *Acta Automatica Sinica*, vol.51(2025) No.3, p.489-509.
- [7] Y.C. Li, Z.J. Liu, Y.T. Hong, et al. Multi-agent reinforcement learning based game: A survey, *Acta Automatica Sinica*, vol.51(2025) No.3, p.540-558.
- [8] X. Wu, Y.H. Wang, B.H. Zhang, et al. Regional air defense and anti-missile weapon-target assignment based on multi-agent reinforcement learning(2025), p.1-12.
- [9] S.H. Li, H. Liu, Z.M. Ren, et al. Task assignment in multi-agent games via reinforcement learning, *Scientia Sinica Technologica*, vol.55(2025) No.5, p.906-913.
- [10] Y. Wang, S.H. Li, B.C. Xu, et al. Multi-agent planning recognition and game encirclement based on data driving, *Transactions of Beijing Institute of Technology*, vol.45(2025) No.5, p.521-530.
- [11] R.N. Wang, Q. Dong: Multiagent game decision-making method based on the learning mechanism, vol.46(2024) No.7, p.1251-1268.
- [12] X.Y. Li, Y.J. Li: Priority-based replanning for multi-agent pathfinding with communication, *Control Theory&Applications*(2024), p.1-10.
- [13] G.M. Mi, H. Zhang, J. Zhang, et al. Multi-agent cooperative confrontation with proximal policy optimization in urban environment, *Journal on Communications*, vol.46(2025) No.3, p.94-108.
- [14] W.B. Gu, X. Zhou, J.G. Wang, et al. Multi-intelligent deep reinforcement learning algorithm for hybrid human-machine collaborative workshop scheduling, *Computer Integrated Manufacturing Systems*(2025), p. 1-29.

- [15] R.N. Qi, Y.M. Quan, Y.N. Ni, et al. Comm-Cot: Standardized chain-of-thought communication framework for efficient LLM based multi-agent decision-making in real-time strategy games, *2025 IEEE 2nd International Conference on Electronics, Communications and Intelligent Science (ECIS)*(Yueyang, China, 2025), p.1-8.
- [16] J. Owotogbe: Assessing and enhancing the robustness of LLM-based multi-agent systems through chaos engineering, *2025 IEEE/ACM 4th International Conference on AI Engineering - Software Engineering for AI (CAIN)*(Ottawa, ON, Canada, 2025), p.250-252.
- [17] Z.G. Yu, C.M. Lu, Q.Y. Liang, et al. Research on an LLM-empowered multi-agent integrated steel scheduling, *Metallurgical Industry Automation*, vol.49(2025) No.4, p.125-133.
- [18] T.T. Shen: *The research on legal question-answering method based on large language models with multi-knowledge bases and multi-agent systems*(MS., Dissertation Submitted for Hangzhou Dianzi University, China 2025, p.27)
- [19] T.T. Yang, P. Feng, Q.X. Guo, et al. AutoHMA-LLM: Efficient task coordination and execution in heterogeneous multi-agent systems using hybrid large language models, *IEEE Transactions on Cognitive Communications and Networking*, vol.11(2025) No.2, p.987-998.
- [20] X.Y. Wu, J.Y. Diao, J.M. Deng. Research on the construction of AI-large-model-based multi-agent energy management system in the HVAC industry, *Software Guide*(2025), p.1-11.
- [21] Z. Yuan: *Research and implementation of multi-agent collaborative decision making method based on federated reinforcement learning*(MS., Beijing University of Posts and Telecommunications, China 2024, p.57)
- [22] X. Yuan, Y. Zhu, J.P. Qiang, et al. Clickbait detection via dual-layer multi-agent large language model, *Computer Systems & Applications*, vol.34(2025) No.5, p.116-123.
- [23] Y.J. Han, W. Wang, Y.F. Zhang, et al. Research on collaborative decision-making method of large and small model under time varying environment, *1st National Conference on Large Language Models and Decision Intelligence*(Hangzhou, China, 2024), p.262-271.
- [24] Z.J. Ding, W.J. Zhang, T.Y. Xu, et al. Deepseek-based multi-intelligent search and quiz on food safety laws and regulations, *Journal of Chinese Institute of Food Science and Technology*, vol.25(2025) No.6, p.449-464.
- [25] P.L. Zhang, Y.X. Ma, H. Li, et al. Large language model driven multi-agents for network intent recognition framework, *Journal of Chinese Computer Systems*(2025), p.1-10.
- [26] I. Chatzistefanidis, A. Leone and N. Nikaen. Maestro: LLM-driven collaborative automation of intent-based 6G networks, *IEEE Networking Letters*, vol.6(2024) No.4, p.227-231.
- [27] Z. Duan and J. Wang. Enhancing multi-agent consensus through third-party LLM integration: Analyzing uncertainty and mitigating hallucinations in large language models, *2025 8th International Conference on Advanced Algorithms and Control Engineering (ICAACE)*(Shanghai, China, 2025), p.2222-2227.
- [28] Y. Sun, Y. Zheng, H.Y. Huang, et al. Multi-loop nested LLM-based multi-agent command and control processes, *Journal of Command and Control*, vol.10(2024) No.6, p.732-739.
- [29] M. De Jesus, P. Sylvester, W. Clifford, et al. LLM-based multi-agent framework for troubleshooting distributed systems, *2025 IEEE Cloud Summit*(Washington, DC, USA, 2025), p.110-115.
- [30] Y.W. Zhang, H.R. Hong, D.S. Zhang, et al. A review of multi-agent-based digital twins and its application in industry, *Control and Decision*, vol.38(2023) No.8, p.2168-2182.
- [31] Y.P. Zhao, J.M. Liang, B.Z. Chen, et al. Research progress and prospects of multi-agent large language models in agricultural applications, *Smart Agricultural*(2025), p.1-15.
- [32] C. Sun, S. Huang, D. Pompili. LLM-based multi-agent decision-making: Challenges and future directions, *IEEE Robotics and Automation Letters*, vol.10(2025) No.6, p.5681-5688.
- [33] T. Zou, X.L. Ding, H.S. Dai, et al. Research on swarm operations decision-making based on large language models, *Journal of Nanjing University of Aeronautics & Astronautics (Natural Science Edition)*(2025), p.1-13.

- [34] W.J. Zheng: *A maintenance knowledge retrieval and multi-agent collaboration framework based on large language models*(MS., Beijing University of Chemical Technology, China 2025, p.43)
- [35] Z.N. Dong, Q.X. Zhang, J. Hu, et al. A multi-dimensional method for large language model-powered multi-agent systems, *Command Control&Simulation*, vol.47(2025) No.2, p.121-131.